

DATE	SYM.	REVISION RECORD	AUTH.	DR.	CHK.

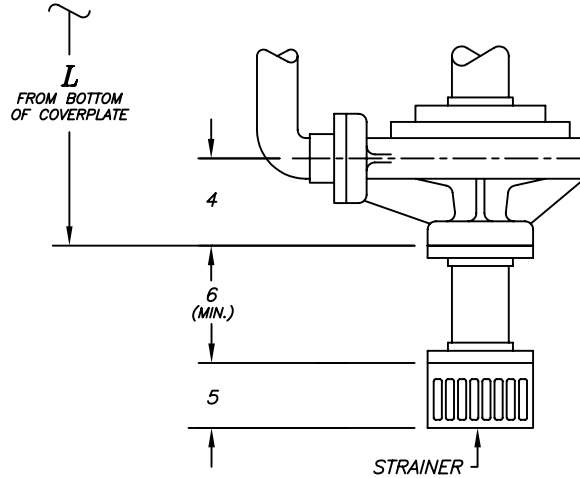

TAILPIPE ASSEMBLY
(OPTIONAL)

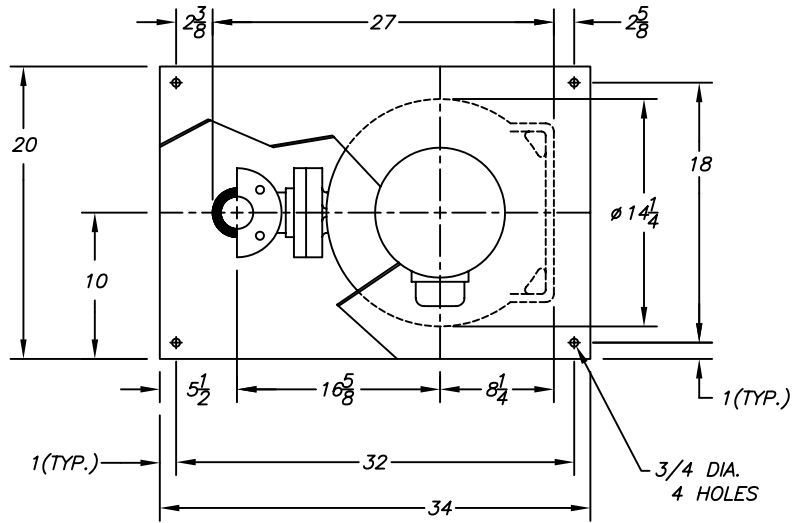
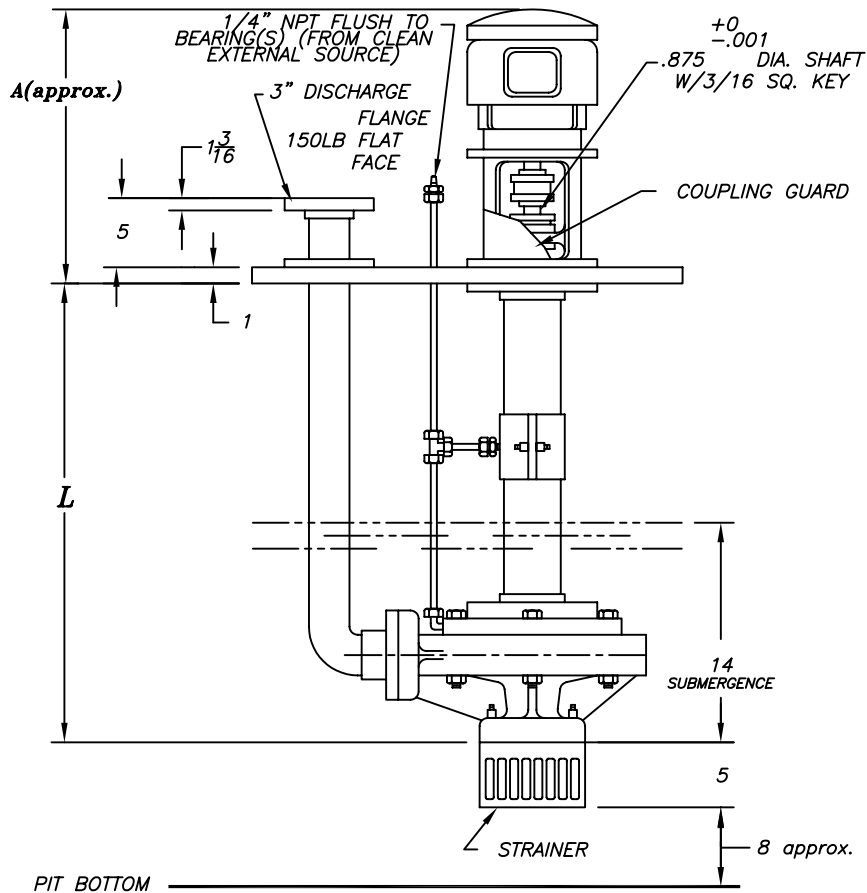

MOTOR FRAME	A
182TC/184TC	26
213TC/215TC	29 3/4
254TC/256TC	35

MOTOR		
HP	RPM	
PH	HZ VOLTS	
ENCL.		
FRAME		

CUSTOMER	
CUST. P.O.#	
TAG:	
FYBROC S/N	

NO.	L	BRGS	WEIGHT APPROX.
1	18-3/8" (1' 6-3/8")	1	-
2	24-3/8" (2' 3/8")	1	-
3	30-3/8" (2' 6-3/8")	1	-
4	36-3/8" (3' 3/8")	1	-
5	42-3/8" (3' 6-3/8")	2	-
6	48-3/8" (4' 3/8")	2	-
7	54-3/8" (4' 6-3/8")	2	-
8	60-3/8" (5' 3/8")	2	-
9	66-3/8" (5' 6-3/8")	2	-
10	72-3/8" (6' 3/8")	3	-
11	78-3/8" (6' 6-3/8")	3	-
12	84-3/8" (7' 3/8")	3	-
13	90-3/8" (7' 6-3/8")	3	-
14	96-3/8" (8' 3/8")	3	-
15	102-3/8" (8' 6-3/8")	4	-
16	108-3/8" (9' 3/8")	4	-
17	114-3/8" (9' 6-3/8")	4	-
18	120-3/8" (10' 3/8")	4	-
19	126-3/8" (10' 6-3/8")	4	-

*-LESS, MOTOR AND TAILPIPE

- NOTES:
1. MOTOR SHIPPED SEPARATELY FOR FIELD MOUNTING BY OTHERS.
 2. ALL DIMENSIONS IN INCHES.
 3. EXPANSION JOINT IS RECOMMENDED FOR DISCHARGE CONNECTION.
 4. COVERPLATE TO BE SUPPORTED ON ALL FOUR SIDES.
 5. ALL FLANGE GASKETS ARE TO BE FULL FACE GASKETS.

Fybroc Division		TEL FORD, PA 18969	
5500 GRP.2 3x4x8		SCALE	DRAWN BY SLJ
		APPROVED BY	
TITLE OUTLINE DRAWING			
DATE 5/10/94	DRAWING NUMBER C40130		REV.

PIT BOTTOM