

DATE	SYM.	REVISION RECORD	AUTH.	D.R.	CK.

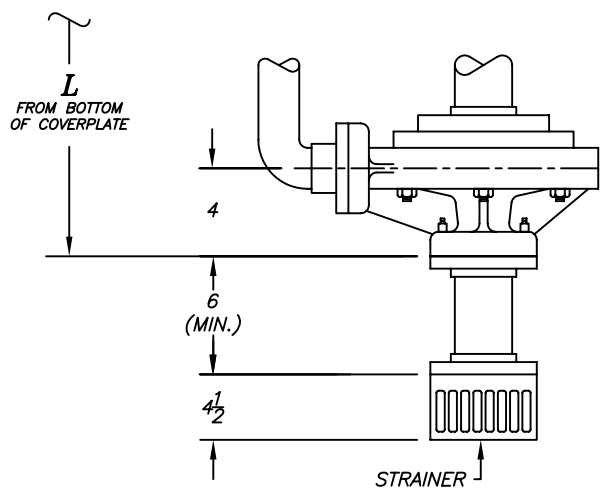

TAILPIPE ASSEMBLY
(OPTIONAL)

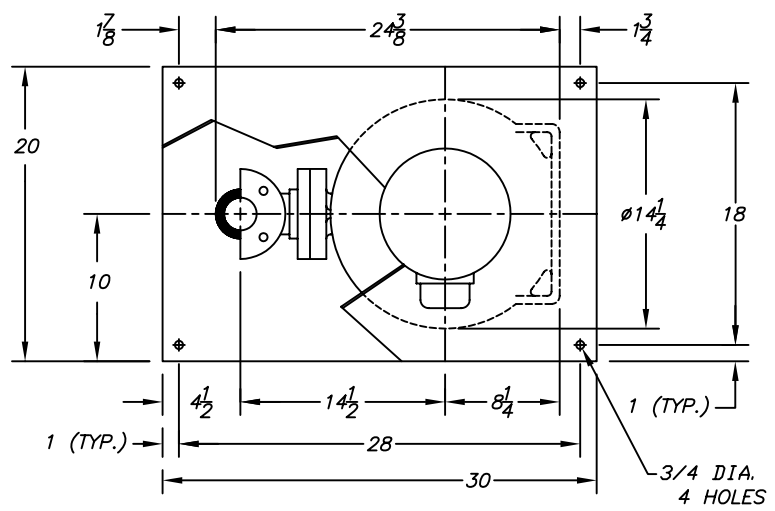
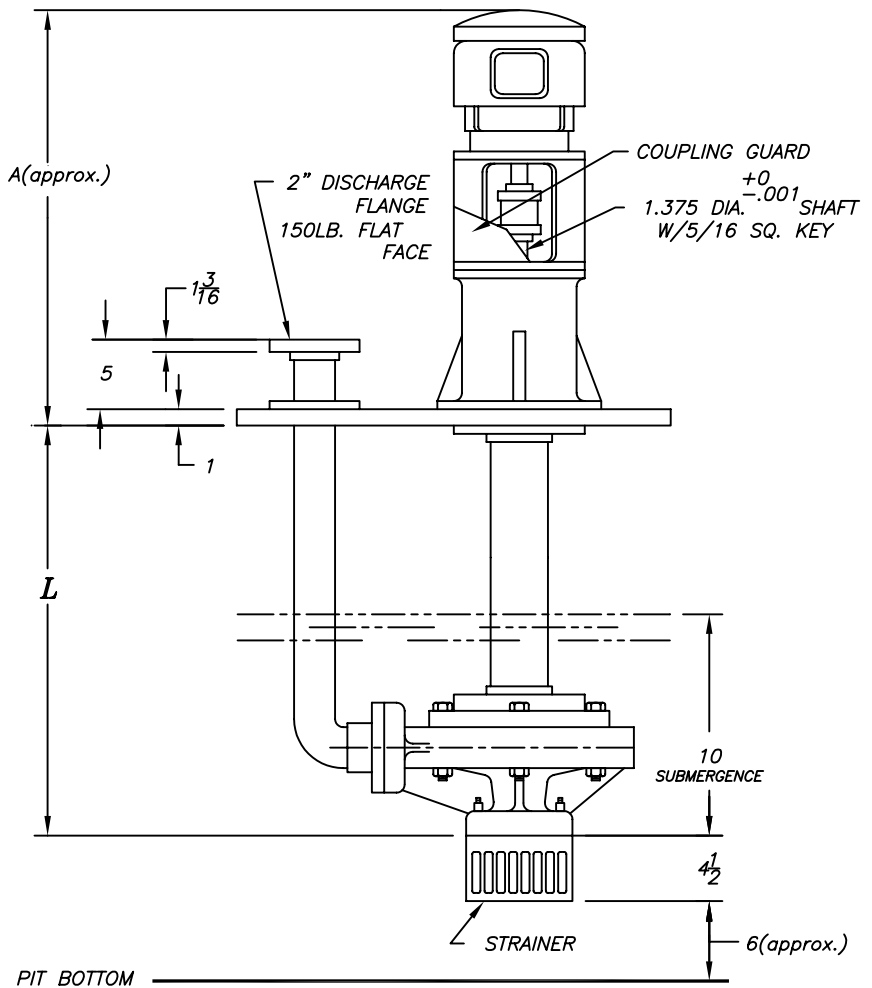

MOTOR FRAME	A
182TC/184TC	38 1/4
213TC/215TC	41 7/8
254TC/256TC	47 1/4

MOTOR		
HP	RPM	
PH	HZ	VOLTS
ENCL.		
FRAME		

CUSTOMER	
CUST. P.O.#	
TAG:	
FYBROC S/N	

- NOTES:
- "L" DIMENSION IS SPECIFIED BY CUSTOMER WHEN ORDER IS ENTERED. "L" MAX.=48"
 - MOTOR SHIPPED SEPARATELY FOR FIELD MOUNTING BY OTHERS.
 - ALL DIMENSIONS IN INCHES.
 - EXPANSION JOINT IS RECOMMENDED FOR DISCHARGE CONNECTION.
 - COVERPLATE TO BE SUPPORTED ON ALL FOUR SIDES.
 - ALL FLANGE GASKETS ARE TO BE FULL FACE GASKETS.

Fybroc Division		TELFORD, PA 18969	
7500 2X3X8	SCALE ~	DRAWN BY <i>SLS</i>	APPROVED BY
TITLE OUTLINE DRAWING			
DATE 5/27/94	DRAWING NUMBER C40141	REV.	

PIT BOTTOM