

DATE	SYM.	REVISION RECORD	AUTH.	DR.	CHK.

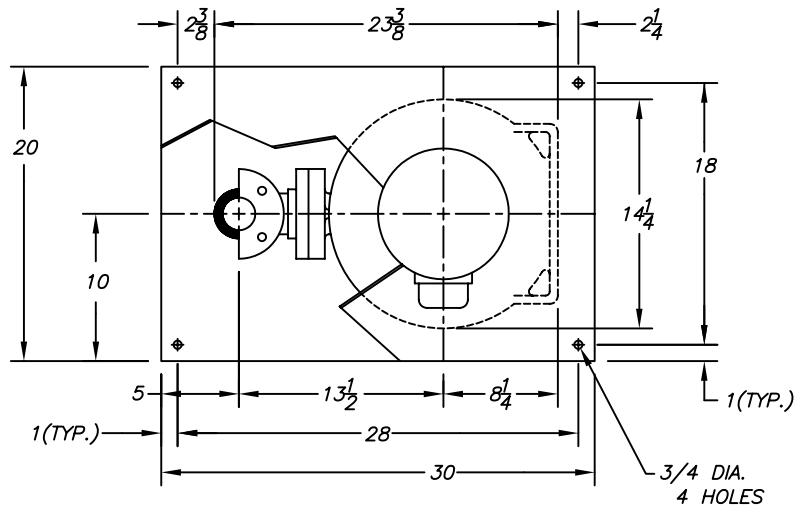

L
FROM BOTTOM
OF COVERPLATE

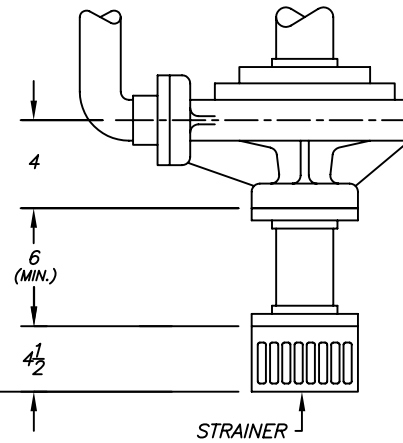

TAILPIPE ASSEMBLY
(OPTIONAL)

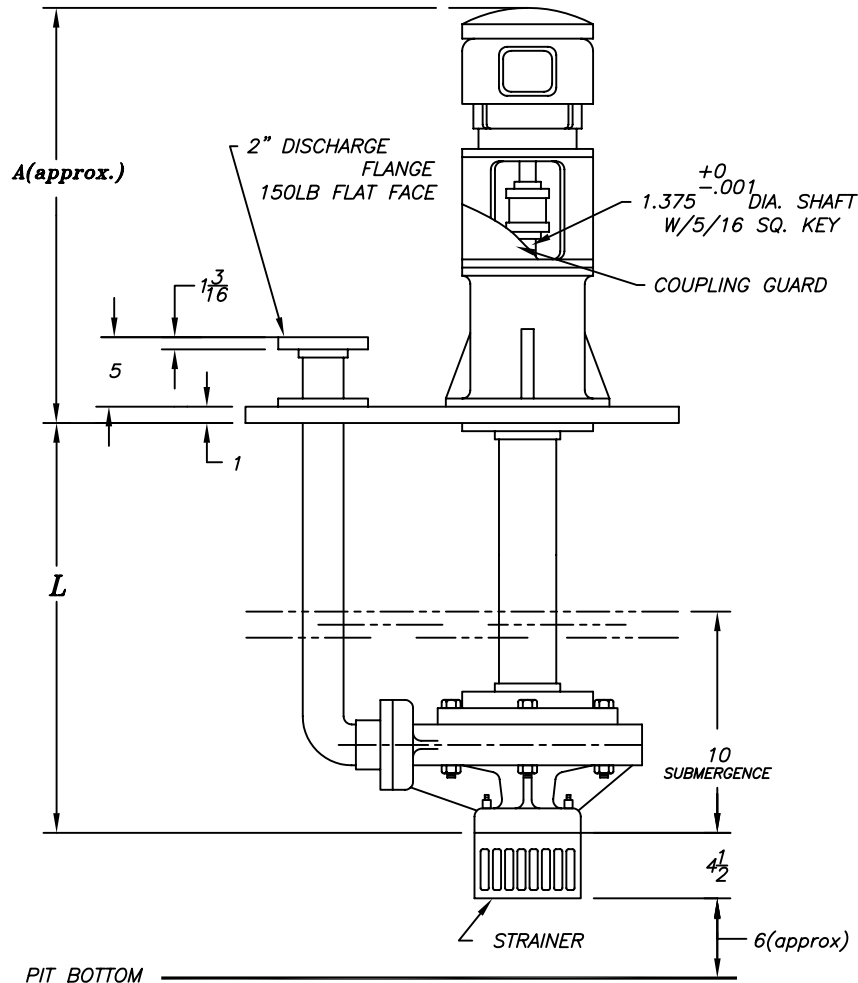

MOTOR FRAME	A
182TC/184TC	38 1/4
213TC/215TC	41 7/8
254TC/256TC	47 1/4

MOTOR		
HP	RPM	
PH	HZ	VOLTS
ENCL.		
FRAME		

CUSTOMER:
CUST. P.O.#
TAG:
FYBROC S/N

NOTES:

- "L" DIMENSION IS SPECIFIED BY CUSTOMER WHEN ORDER IS ENTERED. "L" MAX.=48"
- MOTOR SHIPPED SEPARATELY FOR FIELD MOUNTING BY OTHERS.
- ALL DIMENSIONS IN INCHES.
- EXPANSION JOINT IS RECOMMENDED FOR DISCHARGE CONNECTION.
- COVERPLATE TO BE SUPPORTED ON ALL FOUR SIDES.
- ALL FLANGE GASKETS ARE TO BE FULL FACE GASKETS.

Fybroc Division		TELFORD, PA 18969	
7500	SCALE	DRAWN BY	829
1X2X10		APPROVED BY	
1 1/2X3X10			
TITLE OUTLINE DRAWING			
DATE 5/27/94	DRAWING NUMBER C40143	REV.	